

FERRANTI

FERRANTI TAPCHANGERS LIMITED

DS5

MAINTENANCE PARTS MANUAL ON LOAD TAPCHANGING EQUIPMENT



UNITS 8/9
SOUTHLINK BUSINESS PARK,
HAMILTON STREET
OLDHAM
OL4 1DP
LANCASHIRE
UNITED KINGDOM

TEL:++(0)161 652 2800
FAX:++(0)161 652 5344
EMAIL: sales@ferrantitapchangers.com
WEBSITE: www.ferrantitapchangers.com

ISSUE 2 (JAN 2012)

GENERAL VIEW OF DS5 TAPCHANGER

ITEM 1
TOP TERMINAL COVER GASKET
TC-202630002

ITEM 2
TOP OIL LEVEL SIGHT GASKET
TC-224068003

ITEM 3
TOP OIL LEVEL SIGHT WINDOW
TC-224068002

ITEM 4
OIL SURGE/LOW LEVEL
TERMINAL COVER GASKET
TC-209053

WITH OPTIONAL OIL SURGE / LOW OIL LEVEL RELAY
FITTED.

ITEM 5
AIR RELEASE VALVE
TC-202050

ITEM 7
TOP OIL LEVEL
SIGHT GASKET
TC-202630001

ITEM 6
TOP OIL LEVEL SIGHT WINDOW
TC-202628

ITEM 8
GEARBOX OIL
SIGHT WINDOW
TC-202643

SWITCH COMPARTMENT
(DIVERTER/ SELECTOR)

ITEM 9
GEARBOX OIL LEVEL
SIGHT GASKET
TC-202645

DRIVING MOTOR
AND TIMING
GEAR
COMPARTMENT

HAND OPERATION
SCREWED CAP



GENERAL VIEW OF DS5 TAPCHANGER WITH COVERS REMOVED

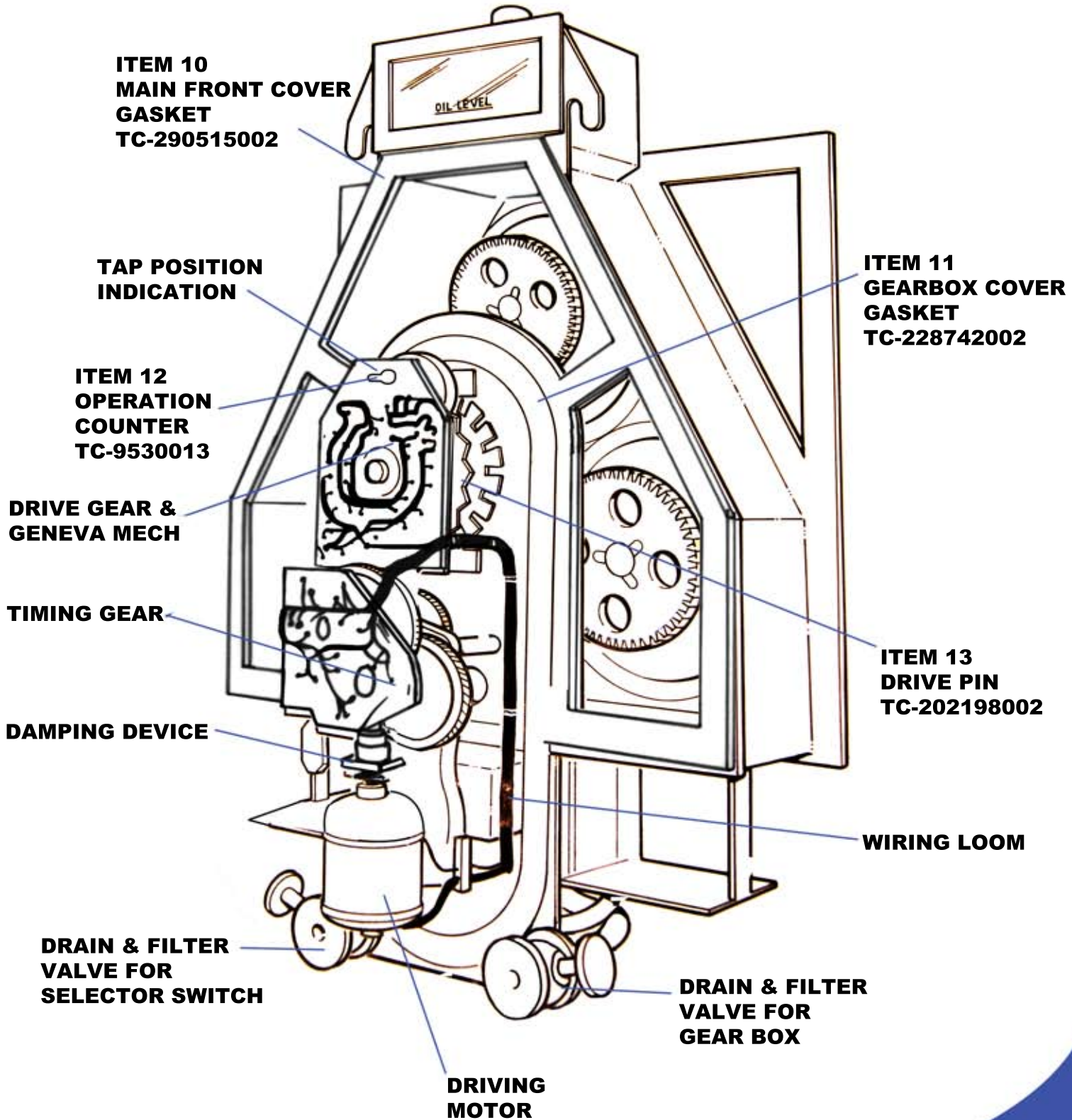

MOVING CONTACT ARM COMPONENTS AND ASSEMBLY

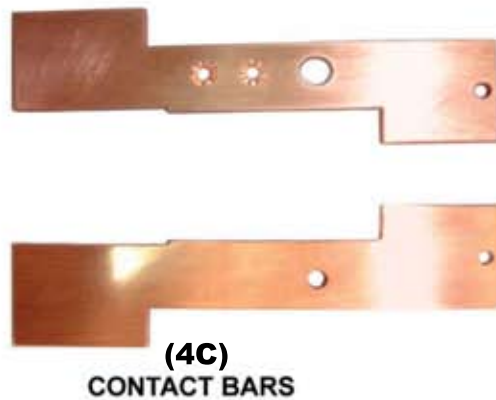
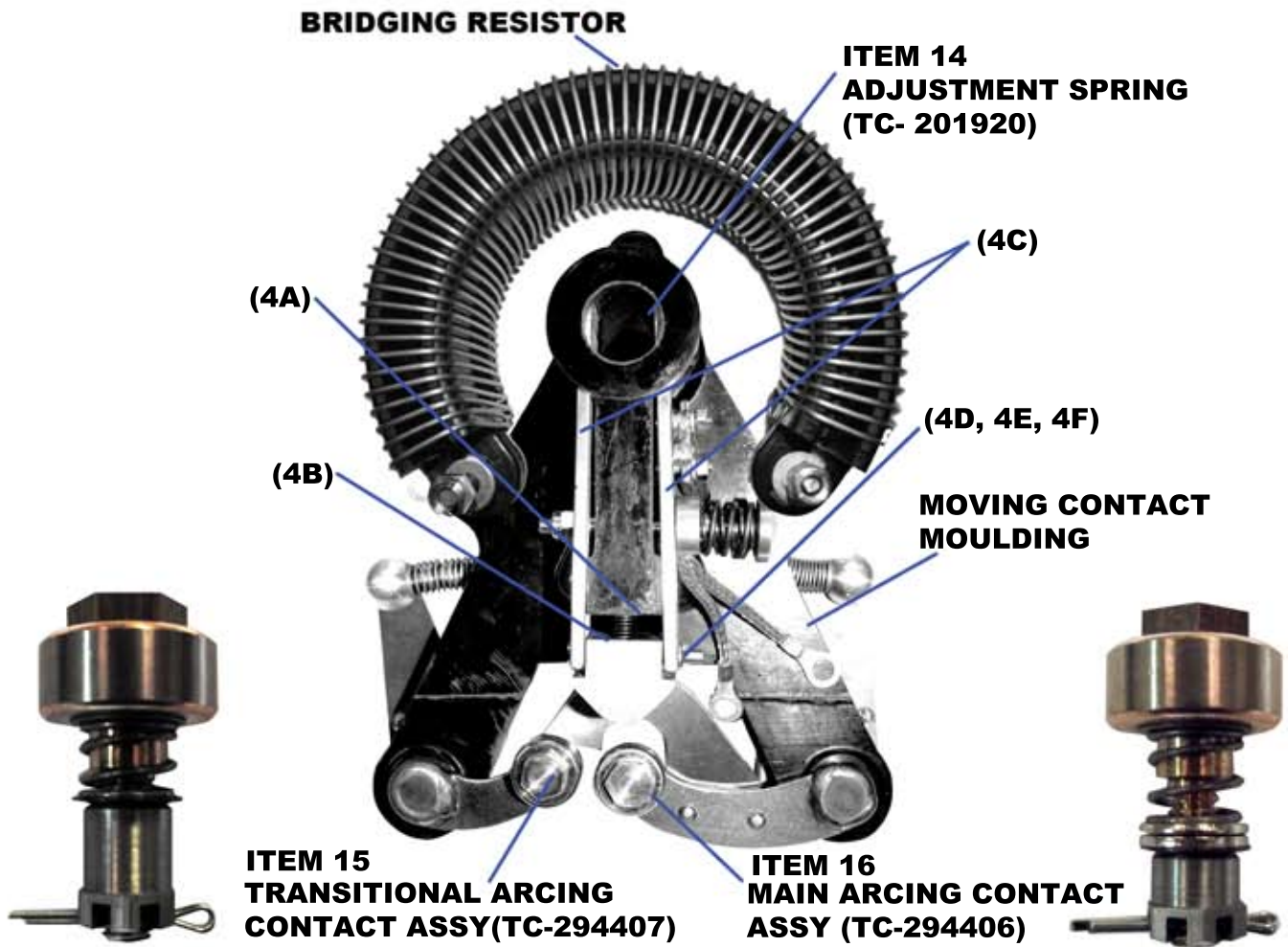

ITEM 17
MAIN CONTACT KIT
TC-294405

COMPRISING

- 4A
- 4B
- 4C
- 4D
- 4E
- 4F



EXPLODED VIEW OF FIXED CONTACT

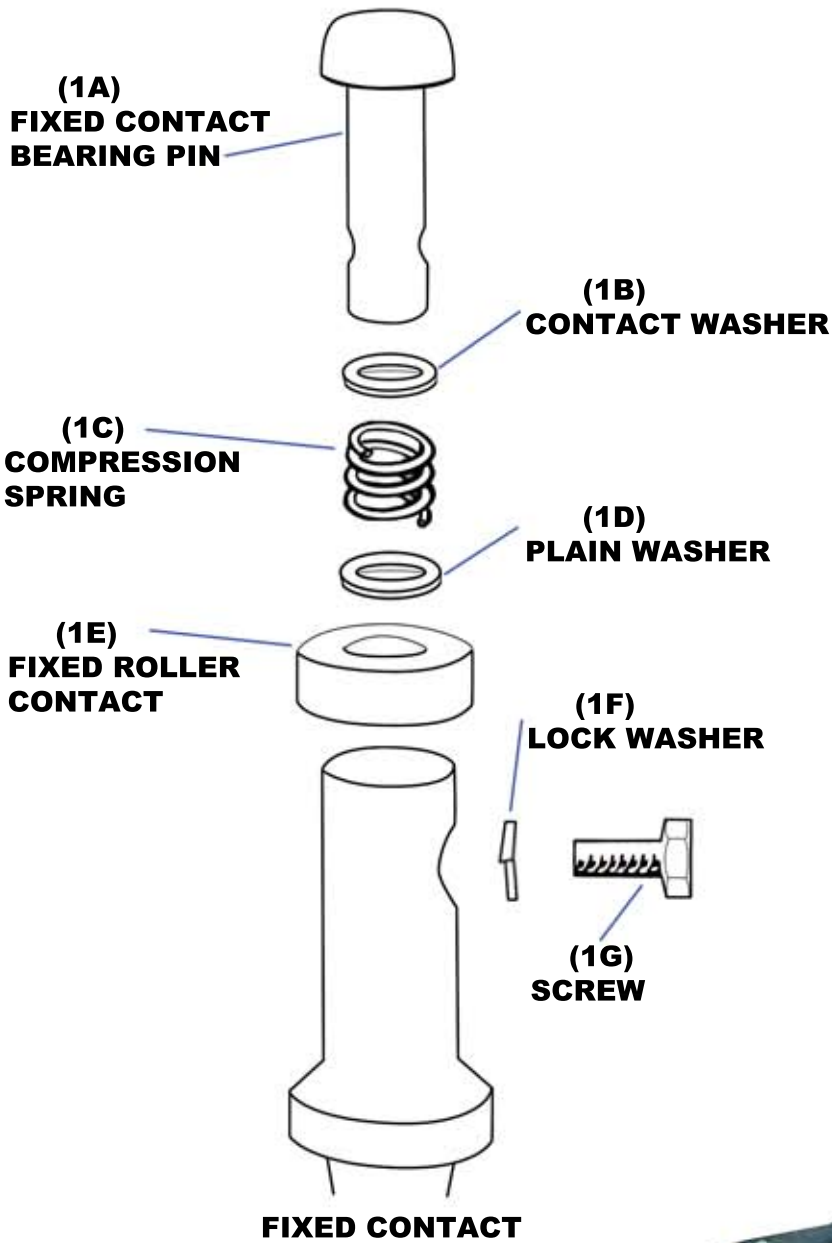

**ITEM 18
FIXED CONTACT KIT
TC-294408**

COMPRISING
1A
1B
1C
1D
1E
1F
1G

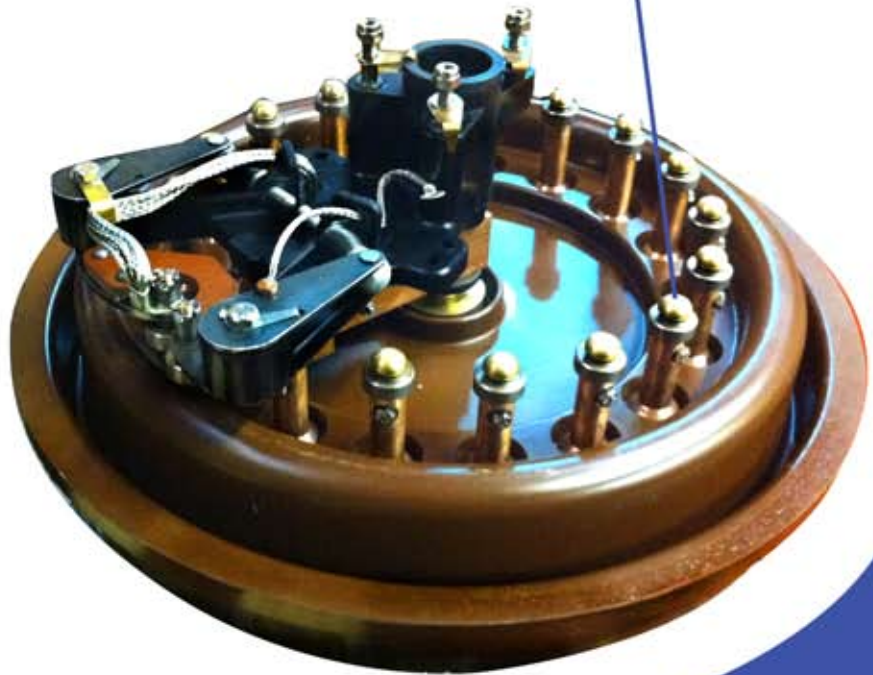

EXPLODED VIEW OF MAIN ARCING CONTACT

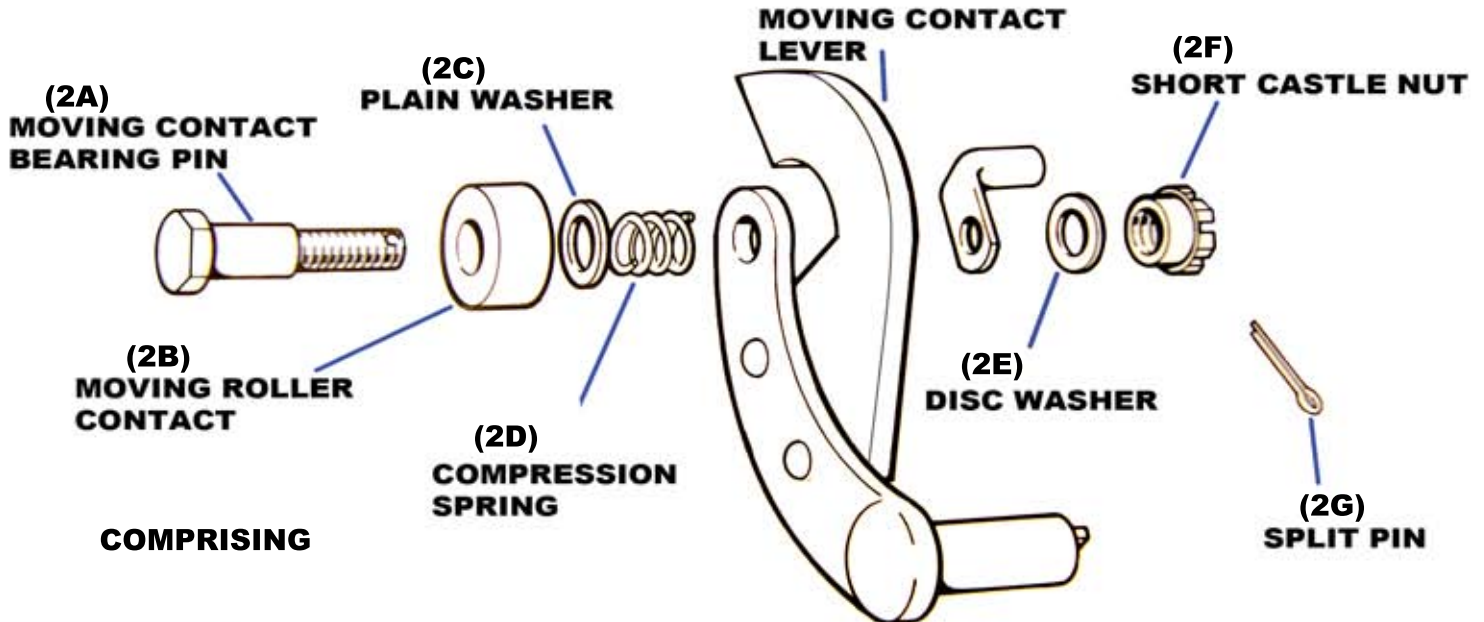

- COMPRISING
- 2A- MOVING CONTACT BEARING PIN
 - 2B- MOVING ROLLER CONTACT
 - 2C- PLAIN WASHER
 - 2D- COMPRESSION SPRING
 - 2E- DISC WASHER
 - 2F- SHORT CASTLE NUT
 - 2G- SPLIT PIN

ITEM 16
ROLLER
CONTACT KIT COMPRISING
SHORT NUT
TC-294407

EXPLODED VIEW OF TRANSITIONAL ARCING CONTACT

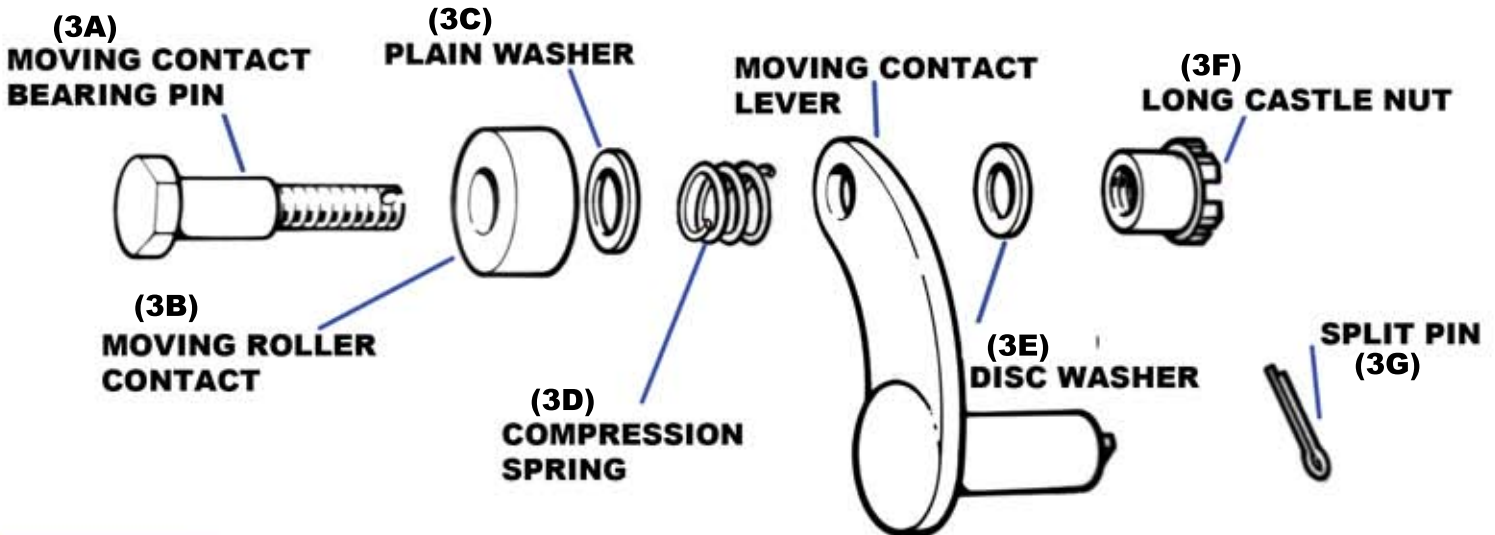

- COMPRISING
- 3A- MOVING CONTACT BEARING PIN
 - 3B- MOVING ROLLER CONTACT
 - 3C- PLAIN WASHER
 - 3D- COMPRESSION SPRING
 - 3E- DISC WASHER
 - 3F- LONG CASTLE NUT
 - 3G- SPLIT PIN

ITEM 15
ROLLER
CONTACT KIT COMPRISING
LONG NUT
TC-294406





**ITEM 12
COUNTER ASSY 5- FIGURE
TC-9530013**

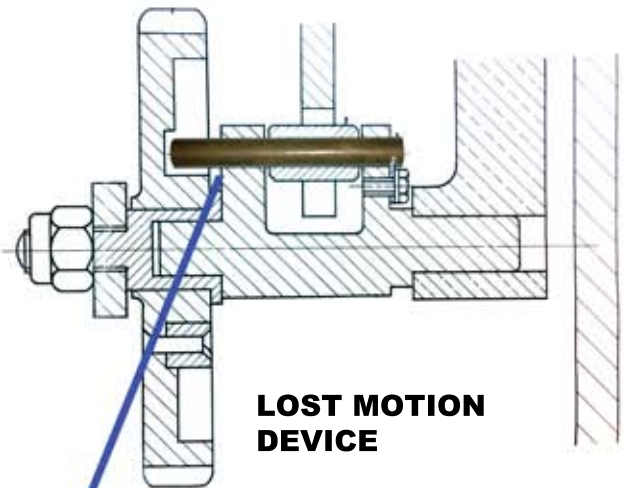
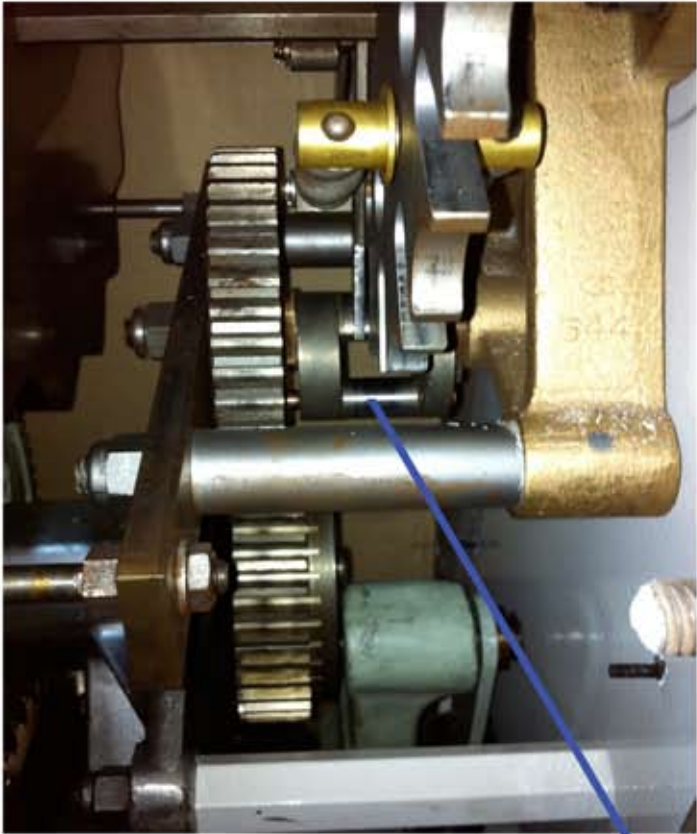

**LOST MOTION
DEVICE**



**ITEM 13
DRIVE PIN
TC-202198002**

FERRANTI TAPCHANGERS LIMITED



DS5

MAINTENANCE PARTS

ITEM	PAGE	PART NUMBER	DESCRIPTION	KIT QTY	QTY REQ
1	2	TC-202630002	TOP TERMINAL COVER GASKET	1	
2	2	TC-224068003	TOP OIL LEVEL SIGHT GASKET	2	
3	2	TC-224068002	TOP TERMINAL SIGHT WINDOW	1	
4	2	TC-209053	OIL SURGE / LOW LEVEL TERMINAL COVER GASKET	1	
5	2	TC-202050	AIR RELEASE VALVE	1	
6	2	TC-202628	TOP OIL LEVEL SIGHT WINDOW	1	
7	2	TC-202630001	TOP OIL LEVEL SIGHT GASKET	2	
8	2	TC-202643	GEARBOX OIL SIGHT WINDOW	1	
9	2	TC-202645	GEARBOX OIL LEVEL SIGHT GASKET	2	
10	3	TC-290515002	MAIN FRONT COVER GASKET	1	
11	3	TC-228742002	GEARBOX COVER GASKET	1	
12	3,7	TC-9530013	OPERATION COUNTER	1	
13	3,7	TC-202198002	DRIVE PIN	1	
14	4	TC-201920	ADJUSTMENT SPRING	3	
15	4,5	TC-294407	MOVING CONTACT ASSY-LONG NUT	3	
16	4,5	TC-294406	MOVING CONTACT ASSY - SHORT NUT	3	
17	4	TC-294405	MAIN CONTACT KIT	3	
18	6	TC-294408	FIXED CONTACT KIT	51	



Why not fax or email a copy of this as your order or enquiry to sales on ++44(0)161 652 5334 (Fax) or sales@ferrantitapchangers.com

PLEASE NOTE: PARTS NOT IDENTIFIED ARE ALSO AVAILABLE EX STOCK

CONTACT

Email: sales@ferrantitapchangers.com
Web Site: www.ferrantitapchangers.com

Ferranti Tapchangers Limited
Unit 8/9 Southlink Business Park,
Hamilton Street,
Oldham,
Lancs
UK
OL4 1DP

Tel: ++44 (0)161 652 2800
Fax: ++44 (0)161 652 5344

